



Pilous

Železná 9, 619 00 Brno, Czech Republic

Tel.: +420 543 25 20 10

e-mail: metal@pilous.cz, www.pilous.cz

ARG 200 plus

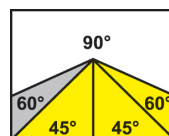

2490 x 20 x 0,9

	90°	-45°	+45°	+60°
●	200	135	155	95
■	200	115	130	65
■	250 x 140	150 x 70	160 x 125	100 x 60

Main motor	400 V, 50 Hz, 0,75/0,95 kW
Pump motor	400 V, 50 Hz, 0,05 kW
Saw blade speed	40/80 m/min.
Working height of vice	900 mm
Coolant tank	cca 15 l
Machine dimensions (min.)	1430 x 750 x 1400 mm
Machine dimensions (max.)	1450 x 1280 x 1980 mm
Machine weight	245 kg

DESCRIPTION

A universal band saw is appraised for general use in various workshops (work on locks, maintenance) and at plants with machinery. Band 20 x 0.9 mm allows for wide use when cutting sections and medium-sized full materials.

The band saw arm uplift is manual; the feed into cut is carried out by the weight of the arm, with the possibility of continuous regulation by the oil damper butterfly valve. When the cut is finished the band saw drive automatically switches off. To facilitate easy arm uplift the machine is equipped with adjustable tension springs that allow for setting of optimum force required for the arm uplift according to characteristics of the material to be cut.

Vice system provides bilateral continuous setting of the cutting angle within the ranges 60° to the right and 45° to the left. The turntable rotates along with the saw band. Thanks to that the saw band does not cut into the loading surface of the vice.

- Robust machine framework composes of castings from grey cast iron and therefore ensures vibration absorption.
- Modern concept of the band saw arm allows for large cutting ranges in upright and angular cuts.
- Simple locking and adjusting of the desired cutting angle on the angle scale with stops fixed at 45°, 60° and 90°.
- Massive quick-clamping vice ensures easy and reliable material clamping.
- Maximum cutting accuracy and saw band service life in this category of band saws.
- High-precision three-side hardmetal band saw guidance.
- Overdesign of running wheel bearings, tensioning wheel system and all rotary parts ensures long service life of the machine.
- Noiseless and maintenance-free band drive is provided by an industrial electric motor with worm gearbox.
- Three-phase two-speed motor (400 V) allows for the selection of band speed between 40 and 80 m/min.
- The machine is connected to a complete cooling system with a high-performance pump and possibility of regulating the flow on both guiding heads independently. Coolant tank with a pump is placed in the base of the machine.
- Easy control by ergonomically placed controls (electrical and hydraulics) on the base of the machine.
- The machine is equipped with a 250 mm workpiece stop.

ACCESSORIES



DR105/130/200/235*

Workpiece stop - Standard equipment

Simple stop for setting the required length of the material to be cut.

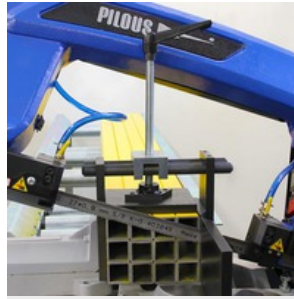

VP

Pressure device

Used to clamp the bundles of material to be cut. Ensures simple and reliable material clamping using a vertical contact pressure.



LA 50

Halogen lamp

Provides good lighting of the workplace of the machine. An invaluable tool especially when the lighting at the workplace is insufficient.



MM

Oil mist lubrication

Creates an oil mist that is sprayed onto the cutting edge. It replaces the use of a classic coolant, especially when cutting sections during which leakages may occur. Possibility of using organic oils.

CONVEYORS

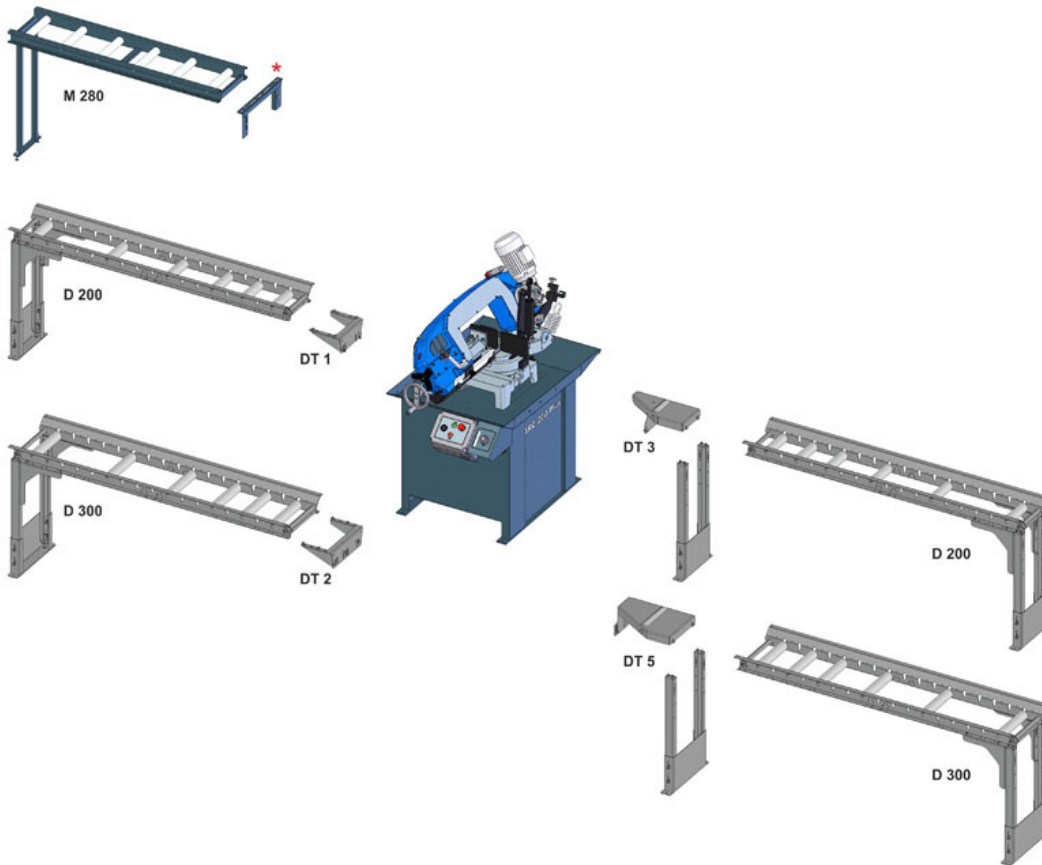

*) Is always a part of the conveyor.

Note: You can connect M280 behind the cut as a conveyor only if angular cutting isn't required.



- Original bandsaw blades produced using the latest technology with top-quality German materials, while strictly complying with all stated production and control procedures.
- High productivity and precision of cut with the maximum service life of the blade is ensured.
- Wide range of produced types of sawblades and tooling enables the professional cutting of almost all available materials.

Bi-metal blade
Consists of bearing band from special steel on which a layer of HSS material is welded into where the teeth are milled.

Constant toothting
The distance of the teeth are always the same.

Variable toothting
The distance of teeth vary and is periodically repeated. This results in a greater cutting range, ability to further eliminate vibrations caused by the impact of the tooth blade on material, longer service life of the blade.

M42

Universal blade recommended for a wide palette of material, including tool steels and stainless steel up to hardness 45 HRC. Teeth are made from steel HSS-M42 containing cobalt.

M51

Blade for tool and stainless steel with hardness up to 50 HRC. Tooth tips are made from steel HSS-M42 containing cobalt and wolfram

Carbide

Consists of bearing band from special steel into which the teeth are milled on which especially grinded carbide plates are welded. The carbide mounted blade is recommended for cutting surface hardened materials, chrome parts, forged pieces and materials with external tenacity and hardness up to 62 HRC.

Cutting range

For optimal output of the blade, the correct selection of the size of the blade tooth is important depending on the size of the divided material.



Variable toothting		Constant toothting		Variable toothting		Constant toothting	
a(D) [mm]		a(D) [mm]		t [mm]		t [mm]	
0-25	10/14	0-10	18	0-4	10/14	0-1	18
20-40	8/12 (8/11)	5-20	14	3-6	8/12 (8/11)	0-3	14
30-60	6/10	20-40	10	6-9	6/10	4-7	10
40-70	5/8 (5/7)	40-80	6	9-13	5/8 (5/7)	8-11	6
60-110	4/6	80-120	4	12-16	4/6	12-15	4
80-140	3/4	120-200	3	16-22	3/4	16-20	3
120-350	2/3	200-400	2	20-35	2/3	21-30	2
250-550	1,4-2	300-800	1,25	30-85	1,4-2	31-90	1,25
380-750	1/1,5			40-85	1/1,5		
550-3000	0,75/1,25			80-200	0,75-1,25		

When selecting the number of teeth for the blade, the general principle applies of a minimum of 4 teeth, but no more than 30 teeth are in contact with the work piece.

Be careful when unpacking welded saw blades. They are in a shipping container in tensioned condition. Remove the saw blade cover only after fitting it onto the machine.



COOLcut Standard

COOLcut Standard – universal coolant and lubricant.

Recommended concentration 5–10 %. 5 litres pack. Dilution 1:20.

- fluid allows achievement of optimal lubricating and cooling properties during the machining process
- low aromatic, highly refined paraffinic oil
- effective corrosion inhibitors provide permanent protection of the workpiece and the machine from corrosion
- bio stability and excellent wettability ensure excellent cooling and lubricating effect even in very hard water
- minimum tendency to foaming ensures effective lubrication
- high efficiency and profitability of use

Except use on log band saws the product is designed for machining operations carried out both on conventional machines and NC and CNC machining centres.



COOLcut Opti

COOLcut Opti – universal coolant and lubricant. Such machining fluid allows achievement of unique lubricating and cooling properties during the machining process.

Recommended concentration 4–7 %. 1 and 5 litres pack. Dilution 1:20.

- low aromatic, highly refined mineral oil
- effective corrosion inhibitors provide permanent protection of the workpiece and the machine from corrosion
- above average stability and excellent wettability ensure excellent cooling and lubricating effect even in very hard water
- minimum tendency to foaming ensures effective lubrication
- high efficiency and profitability of use
- long-term biostability

In addition to use in saw bands the product is designed for machining operations carried out both on conventional machines and NC and CNC machining centres.



COOLcut Eco 65

COOLcut Eco 65 – universal cooling and lubricating emulsifying oil, well biodegradable according to OECD 301-D test. Biodegradability of 65 % in 21 days.

Recommended concentration 4–7 %. 5 litres pack. Dilution 1:20.

- Such machining fluid allows achievement of unique lubricating and cooling properties during the machining process
- highly refined synthetic ester oil
- effective corrosion inhibitors provide permanent protection of the workpiece and the machine from corrosion
- above average stability and excellent wettability ensure excellent cooling and lubricating effect even in very hard water
- minimum tendency to foaming ensures effective lubrication
- high efficiency and profitability of use
- long-term biostability

In addition to use in saw bands the product is designed for machining operations carried out both on conventional machines and NC and CNC machining centres.



COOLcut Bio 90

COOLcut Bio 90 – universal cooling and lubricating emulsifying oil, well biodegradable according to OECD 301-D test. Biodegradability of 90 % in 21 days. Due to its biodegradability it can be used in any outdoor environment without environmental damage.

Recommended concentration 4–7 %. 5 litres pack. Dilution 1:20.

- Such machining fluid allows achievement of unique lubricating and cooling properties during the machining process
- highly refined synthetic ester oil
- effective corrosion inhibitors provide permanent protection of the workpiece and the machine from corrosion
- above average stability and excellent wettability ensure excellent cooling and lubricating effect even in very hard water
- minimum tendency to foaming ensures effective lubrication
- high efficiency and profitability of use
- long-term biostability

In addition to use in saw bands the product is designed for machining operations carried out both on conventional machines and NC and CNC machining centres.



COOLcut Micro

COOLcut Micro – an easily biodegradable semi-synthetic cooling and lubricating micro-emulsion. Due to its biodegradability it can be used in any outdoor environment without environmental damage. Such machining fluid allows achievement of unique lubricating and cooling properties during the machining process.

Pack of 5 litres. Use undiluted.

- highly refined synthetic ester oil
- effective corrosion inhibitors provide permanent protection of the workpiece and the machine from corrosion
- above average stability and excellent wettability ensure excellent cooling and lubricating effect even in very hard water
- minimum tendency to foaming ensures effective lubrication
- high efficiency and profitability of use
- long-term biostability

In addition to use in saw bands the product is designed for machining operations carried out both on conventional machines and NC and CNC machining centres. 5 litres pack.



COOLcut Antifreeze

COOLcut Antifreeze – low-freezing ingredient for water miscible coolants used in winter in outdoors environment, up to minus 20 °C, depending on the dosage.

5 litres pack. Dilution 1:20.

- effectively lowers the freezing point of the fluid
- very good resistance to oxidation guarantees long service life
- does not act aggressively on the sealing elements (elastomers), to which it comes into contact.

Optima Antifreeze	(%)	10	20	30	40	50
Flowability temperature	(°C)	-5	-10	-17	-26	-40

RECOMMEND



OH 90

Simple and very fast deburring of all kinds of sections (including the internal edges) or full material by a rotary steel brush. High quality construction of the machine along with a three-phase motor make use of the machine possible in specialized workshops as well as in production plants. Compared to manual deburring it reduces the required time and hence reduces your costs. While maintaining incomparably higher and balanced quality of deburring.

We recommend using stainless steel brush for stainless steel products.
Example of the difference between manual deburring (including internal edges) and OH 90

Hollow section 60 x 60 x 2 mm:	manual deburring - 32 s	machine OH 90 - 8 s
Tube diameter 50 x 2 mm:	manual deburring - 21 s	machine OH 90 - 4 s



OHE 90

Simple and very fast deburring of all kinds of sections (including the internal edges) or full material by a rotary steel brush. High quality construction of the machine along with a three-phase motor make use of the machine possible in specialized workshops as well as in production plants. Compared to manual deburring it reduces the required time and hence reduces your costs. While maintaining incomparably higher and balanced quality of deburring.

We recommend using stainless steel brush for stainless steel products.
Example of the difference between manual deburring (including internal edges) and OH 90

Hollow section 60 x 60 x 2 mm:	manual deburring - 32 s	machine OH 90 - 8 s
Tube diameter 50 x 2 mm:	manual deburring - 21 s	machine OH 90 - 4 s